

# Skein valued curve counts, basic disks, and HOMFLY homology

Tobias Ekholm

Uppsala University and Institut Mittag-Leffler, Sweden

Perspectives on knot homology  
May 18, 2021

*This talk reports on various joint works: with Shende, Kucharski, Longhi, Georgieva, Ng*

Plan:

- Skein valued open GW-invariants and large N duality
- Skein recursion
- The toric brane and basic disks
- Other basic curves
- Refined partition functions and consequences for HOMFLY homology

## Geometric setting:

- $(X, \omega)$  3-dim symplectic Calabi-Yau,  $c_1(X) = 0$ .  
Main examples:  $\mathbf{C}^3$ ,  $T^*S^3$ , and  $\mathcal{O}(-1)^{\oplus 2} \rightarrow \mathbf{C}P^1$ .
- $L \subset X$  Maslov zero Lagrangian.  
Main examples: toric brane, knot conormals, 0-section.

## Holomorphic curves:

- $J$  acs on  $X$  compatible with  $\omega$ .  $(S, j)$  Riemann surface. A *holomorphic curve* is a map  $u: (S, \partial S) \rightarrow (X, L)$  that solves the Cauchy-Riemann equation:  $\bar{\partial}_J u = \frac{1}{2}(du + J \circ du \circ j) = 0$ .
- The Cauchy-Riemann equation is Fredholm and the expected dimension of the moduli space of solutions is

$$(\dim_{\mathbf{C}} X - 3)\chi(S) + 2c_1^{\text{rel}}(u^* TX) = 0 + 0.$$

# Skeins on branes

The dimension count indicates that after perturbation, the moduli space of solutions to the Cauchy-Riemann equation is an oriented zero-manifold. For closed curves nodal solutions appear in codim 2 and curve counts are invariant under deformation. For open curves boundary nodes have codimension one and curve counts are not invariant. There are invariant curve counts in this setting, in the skein.

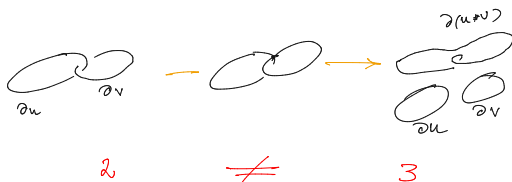

For general curves we use the HOMFLY skein. For curves invariant under an involution that fixes the Lagrangian we use the Kauffmann skein.

# Skews on branes

$\mathbb{Q}[a^\pm, z^\pm]$  - modules (or  $\mathbb{Q}[a^\pm, q^{\pm 1/2}]$ ,  $z = q^{1/2} - q^{-1/2}$ )

HOMFLY  
oriented framed links

$$\begin{array}{c} \nearrow \searrow \\ \times \end{array} - \begin{array}{c} \nearrow \nearrow \\ \times \end{array} = z \begin{array}{c} \curvearrowright \\ \curvearrowleft \end{array}$$

$$a - a^{-1} = z \bigcirc$$

$$\begin{array}{c} \uparrow \\ \circlearrowleft \end{array} = a \uparrow \quad \begin{array}{c} \uparrow \\ \circlearrowright \end{array} = a^{-1} \uparrow$$

Kauffman  
unoriented framed links

$$\begin{array}{c} \times \\ \times \end{array} - \begin{array}{c} \times \\ \times \end{array} = z \left( \begin{array}{c} \curvearrowright \\ \curvearrowleft \end{array} - \begin{array}{c} \curvearrowleft \\ \curvearrowright \end{array} \right)$$

$$a - a^{-1} = z \left( \bigcirc - \bigcirc \right)$$

$$\begin{array}{c} \uparrow \\ \circlearrowleft \end{array} = a \uparrow \quad \begin{array}{c} \uparrow \\ \circlearrowright \end{array} = a^{-1} \uparrow$$

For example,  $\text{Sk}(S^3) = \mathbf{C}[q^{\pm 1}, a^{\pm 1}]$ ,  $\text{Sk}(S^1 \times \mathbf{R}^2)$  is a free commutative algebra on countably many generators  $A_m$  ( $m - 1$  crossings,  $m$  times around).

# Skeins on branes

**Bare curves:** A stable map  $u: S \rightarrow X$  is *bare* if all its irreducible components have positive symplectic area.

Skein valued curve counts are based on counting bare holomorphic curves by their boundary in the framed skein.

**Auxiliary framing data:** Generic vector field  $\xi$  on  $L$  and 4-chain  $C$  with  $\partial C = 2 \cdot L$  and  $\pm J \cdot \xi$  along the boundary.

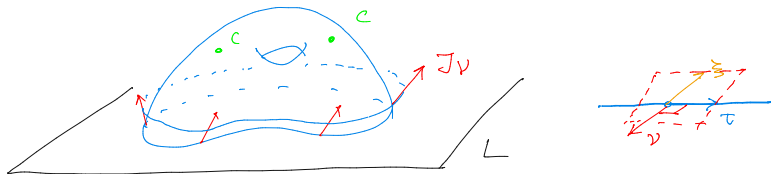

$$\text{lk}(L, u) = u_{Jv} \cdot C$$

The skein valued curve count is then a sum over all disconnected bare holomorphic curves where the contribution of  $u: (S, \partial S) \rightarrow (X, L)$  is

$$w(u) z^{-\chi(S)} a^{\text{lk}(L,u)} \langle u(\partial S) \rangle \in \text{Sk}(L)$$

- $w(u)$  – rational weight of  $u$  as a weighted point in the moduli space
- $\chi(S)$  – Euler characteristic of  $S$
- $\text{lk}(L, u)$  – linking between  $u$  and  $L$
- $\langle u(\partial S) \rangle$  – the boundary of  $u$  in the skein of  $L$ .

# Skeins on branes

The skein valued curve count is invariant under deformations. This is proved by constructing a perturbation scheme for the Cauchy-Riemann equation. A cartoon version is as follows.

$$\begin{array}{ccc}
 \begin{array}{c} \text{Diagram of a sphere with two small circles on top and a dashed line indicating a cut.} \\ \text{---} \end{array} & \xrightarrow{u} & (\mathbb{R}^b, \mathbb{R}^3; J) \\
 & & \int |D^k u|^2 e^{S_0} dA \\
 & & Z_{\mathbb{R}^b}(S_0) \\
 & & TZ_{\mathbb{R}^b} \\
 v \rightarrow e^{-S_0} v \xrightarrow{\bar{\partial}_J} e^{-S_0} \bar{\partial}_J v \rightarrow \bar{\partial}_J v & \text{converges to} & \\
 v \rightarrow \bar{\partial}_{J_0} v = T\bar{\partial}_J & \text{as } S_0 \rightarrow \infty. & 
 \end{array}$$

Configuration space for bare maps with ghosts.

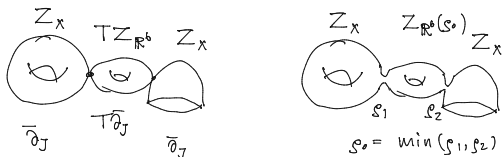



# Skeins on branes

Define, inductively in Euler characteristic, a (multi-) section  $\lambda: \mathbf{Z} \rightarrow \mathbf{W}$ , which is zero on ghost components and which have the following properties:

- 1) Bare solutions transversely cut out, embeddings, tangent along boundary spans together with  $\xi$  a 2-plane everywhere.
- 2) Constant curves bubble off only in codimension  $\geq$  two  
 $\Rightarrow$  for 1-parameter families, all solutions near boundary are bare with ghosts.



# Skews on branes

3) Degeneracies in 1-parameter families of solutions have standard form.

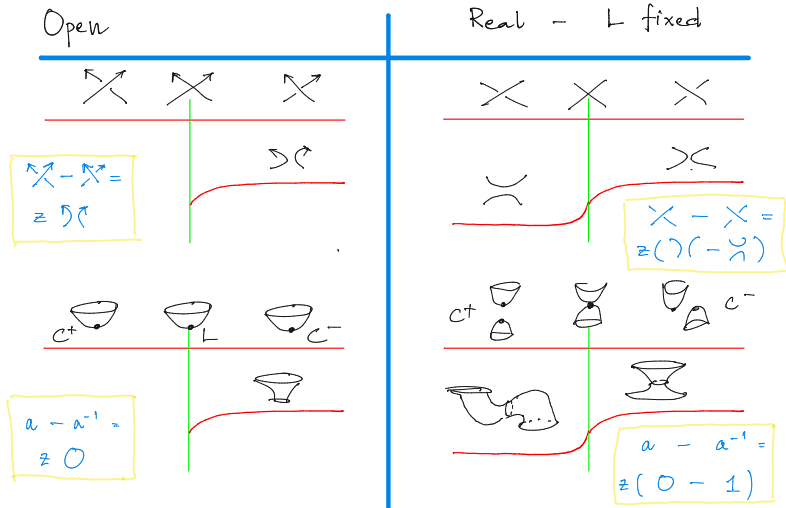

4) At tangencies with  $\xi$  a kink is traded for a 4-chain intersection.



$$\uparrow \rho = a \uparrow \quad \uparrow \rho = a^{-1} \uparrow$$

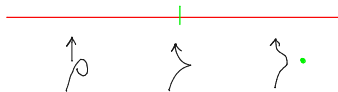

Skein counts are inductive in Euler characteristic. Usual perturbative treatment is not.



With  $z = (q - q^{-1})$  the bare curve count is like the first term ( $d=1$ ) in the GV formula for the contribution to GW from a curve of Euler characteristic  $\chi$  in homology class  $x$ :

$$\exp \left( \sum_{d=1}^{\infty} \frac{x^d}{d} (q^d - q^{-d})^{-\chi} \right)$$

# Ooguri-Vafa large N duality

**Geometric setup:**  $K \subset S^3$  – knot.  $L_K \subset T^*S^3$  – Lagrangian conormal  $\approx S^1 \times \mathbf{R}^2$ . Shift  $L_K$  off of 0-section  $S^3$  (non-exact). Transition to resolved conifold  $X = \{\mathcal{O}(-1)^{\oplus 2} \rightarrow \mathbf{C}P^1\}$ .

$$\{z_1^2 + z_2^2 + z_3^2 + z_4^2 = 0\}$$

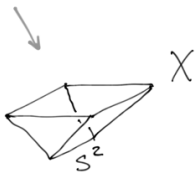
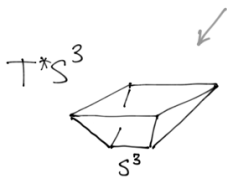
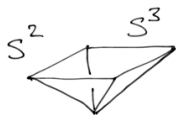

## Theorem

*The GW partition function equals the generating function for the colored HOMFLY:*

$$\Psi_K(x, a, g_s) = \sum_{k \geq 0} H_{K,n}(a, e^{\frac{g_s}{2}}) e^{nx},$$

# Ooguri-Vafa large N duality

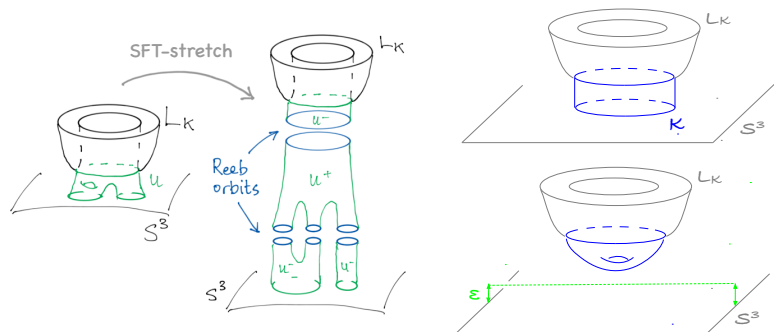

For a small shift of the conormal there is a unique holomorphic cylinder. SFT stretching removes all boundaries from the 0-section (outside curves asymptotic to Reeb orbits of index 2 gives negative dimension). Calculating the skein valued invariant gives the colored HOMFLY (obvious for once around, for many times we use info about the unknot). Curves in the stretched structure are the same as in the conifold for small area  $\mathbf{CP}^1$ . □



Moduli spaces for planar unknot.

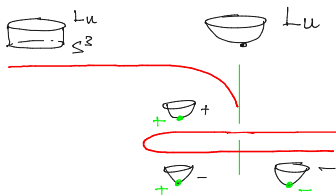

*Real curves* can be counted as in ordinary GW theory. For any knot  $K$  the count in the basic homology class in  $H_2(T^*S^3; L_K \cup S^3)$  is one cylinder, i.e., 1. The skein count corresponds in the stretched picture to a count in  $H_2(T^*S^3 \setminus S^3; L_K)$  and equals the Kauffman polynomial by the argument above.

# Large N duality – comments

The argument works for conormals  $L_K \subset T^*M$  of knots in any oriented 3-manifold  $M$  but since  $\pi_1(M) \neq 1$  there are index zero geodesics and holomorphic curves generally has inside pieces after stretching. This leads to a universal skein GW invariant with values in

$$Q \otimes \text{Sk}(M),$$

where  $Q$  is the kernel of a differential operator  $D(a, z)$  on the algebra of degree 0 Reeb orbits.

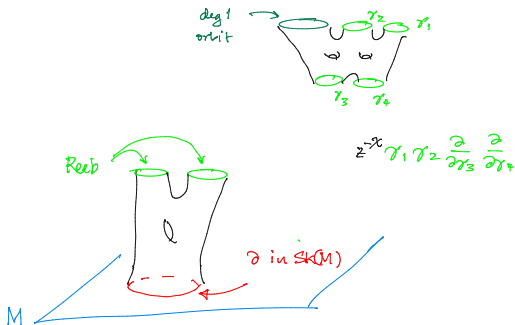

# The toric brane in $\mathbf{C}^3$

The toric brane in  $\mathbf{C}^3$  provides a universal model for 'crossing a basic disk' and illustrates how to calculate skein invariants 'from infinity'.

**Strategy for curve counts from infinity:**  $(X, L)$  has ideal contact boundary  $(\partial X, \partial L)$ . The boundary of 1-dimensional moduli spaces consists of  $\mathbf{R}$ -invariant curves at infinity and rigid curves in the bulk. The boundary is zero in the skein. The outside then determines the inside.

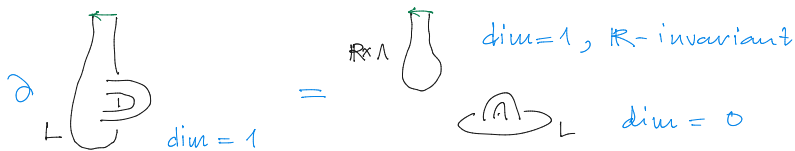

# The toric brane in $\mathbf{C}^3$

$\mathbf{C}^3$  with coordinates  $z = (z_1, z_2, z_3)$ .

$\mathbf{C}^3 \rightarrow \mathbf{R}^3$ ,  $z \mapsto (r_\alpha(z), r_\beta(z), r_\gamma(z))$ ,

$$r_\alpha(z) = |z_1|^2 - |z_2|^2, \quad r_\beta(z) = |z_2|^2 - |z_3|^2, \quad r_\gamma(z) = \text{Im}(z_1 z_2 z_3).$$

Fiber at  $(r_\alpha, r_\beta, r_\gamma)$ :

$$\begin{aligned} |z_1|^2 &= r_\alpha + |z_3|^2, & |z_2|^2 &= r_\beta + |z_3|^2, \\ \text{Im}(|z_1||z_2||z_3|e^{i(\theta_1+\theta_2+\theta_3)}) &= r_\gamma \end{aligned}$$

$\Rightarrow$  generic fiber  $T^2 \times \mathbf{R}$ .

# The toric brane in $\mathbf{C}^3$

Lagrangians  $L_1, L_2, L_3 \approx S^1 \times \mathbf{R}^2$ .

$$L_1: r_\alpha = 0, r_\beta = r_1^*, r_\gamma \geq 0 \text{ and } \operatorname{Re}(z_1 z_2 z_3) = 0,$$

$$L_2: r_\beta = 0, r_\alpha = r_2^*, r_\gamma \geq 0 \text{ and } \operatorname{Re}(z_1 z_2 z_3) = 0,$$

$$L_3: r_\alpha - r_\beta = 0, r_\alpha = r_3^*, r_\gamma \geq 0 \text{ and } \operatorname{Re}(z_1 z_2 z_3) = 0,$$

We restrict attention to  $L_1$  and parameterize it

$$\left( |z_3| e^{i\theta}, (|z_3| + r_1^*) e^{i\phi}, |z_3| e^{-i(\theta + \phi - \frac{\pi}{2})} \right)$$

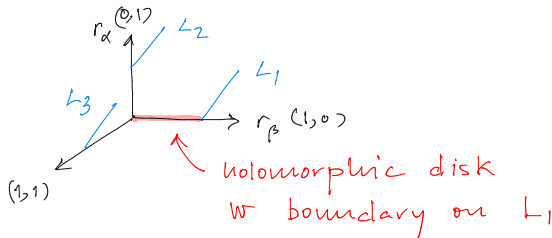

As  $|z_3| \rightarrow \infty$ ,  $L_1$  is asymptotic to the  $\mathbf{R}$ -invariant Lagrangian

$$\left( \rho e^{i\theta}, \rho e^{i\phi}, \rho e^{-i(\theta+\phi-\frac{\pi}{2})} \right).$$

Consider the image under the Hopf map  $S^5 \rightarrow \mathbf{C}P^2$ :

$$[e^{i(2\theta+\phi)} : e^{i(2\phi+\theta)} : i].$$

A Clifford torus and the Legendrian  $\partial L_1$  is a 3-fold cover (Bohr-Sommerfeld). The Reeb chords of  $\partial L_1$  are Bott degenerate and come in  $T^2$ -families, length  $k\frac{2\pi}{3}$ , index  $\geq 1$ , with equality only for  $k = 1$ .

# The toric brane in $\mathbb{C}^3$

To find holomorphic curves one can either use curves on the Clifford torus or draw the front of  $\partial L_1$  in  $\mathbb{R}^5 \subset S^5$ :

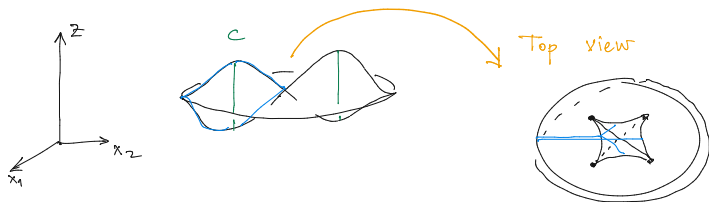

$S^1$ -disks, boundaries as follows

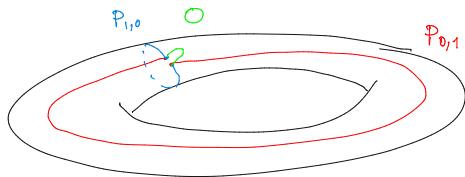

We learn then that the skein valued curve count  $\Psi$  on the toric brane satisfies the operator equation:

$$(\bigcirc - P_{1,0} - P_{0,1})\Psi = 0.$$

The operators  $\bigcirc - P_{1,0}$  and  $P_{0,1}$  have a common eigen-basis in the positive skein  $W_\lambda$  where  $\lambda$  runs over partitions of positive integers. The operator equation has a unique solution in  $\text{Sk}^+$ :

$$\Psi = \sum_{\lambda} W_{\lambda} \prod_{\square \in \lambda} \frac{q^{-c(\square)/2}}{q^{h(\square)/2} - q^{-h(\square)/2}},$$

where  $h$  is the hook length and  $c$  the content, here we use  $z = q^{1/2} - q^{-1/2}$ .



Interpretation of the equation

$$(\circlearrowleft - P_{1,0} - P_{0,1}) \Psi = 0.$$

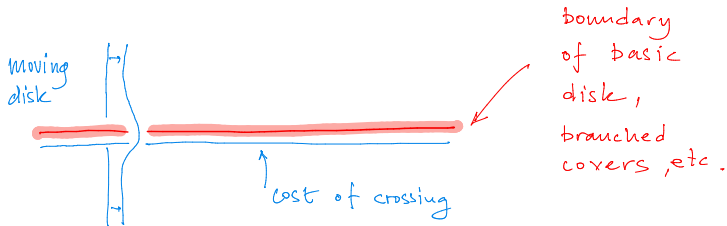

The standard approach to open GW invariants with one copy of the Lagrangian correspond to  $U(1)$  gauge theory and in the case of bare curves to  $a = q = e^{g_s}$  after projection to 'homology + linking', we call them *generalized curves*.

$$w(u) z^{-\chi(S)} a^{\text{lk}(L,u)} \langle u(\partial S) \rangle \in \text{Sk}(L) \rightarrow$$

$$w(u) (q - q^{-1})^{-\chi(S)} q^{\text{lk}(L,u)} [u(\partial S)] \in \mathbf{Q}[q^{\pm}][\widehat{H_2(X, L)}]$$

E.g., for the toric brane and the recursion relation then reads:

$$(1 - e^{\hat{x}} - e^{\hat{p}})\psi(x) = 0, \quad \psi(x) = \sum_k c_k(q)e^{kx},$$
$$c_k(q) = (1 - q)^{-1}(1 - q^2)^{-1} \dots (1 - q^k)^{-1},$$

where  $x$  generates  $H_1(L)$  and  $\log a$  generates  $H_2(X)$ ,  $e^{\hat{x}}$  is multiplication by  $e^x$  and  $e^{\hat{p}} = e^{g_s \partial_x}$ .

# Basic holomorphic disks and quivers

It was observed that the generating function for the colored HOMFLY can be written as a quiver partition function for a symmetric quiver. The geometry behind such expressions can be understood if we assume that there is a finite set of basic holomorphic disks (the quiver nodes) attached to  $L_K$  such that all holomorphic curves lie in a neighborhood of  $L_K \cup \{\text{basic disks}\}$ .

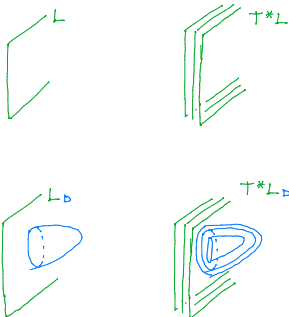

# Basic holomorphic disks and quivers

As for generalized curves, we must keep track of the linking number between disks to count generalized curves. The result is an expression of the following form:

$$\begin{aligned}\Psi_K(e^x, a, q) &= \psi\left(e^{x_1} e^{\sum_{j=1}^n C_{1j} g_s \partial x_j}\right) \cdots \psi\left(e^{x_m} e^{\sum_{j=1}^n C_{mj} g_s \partial x_j}\right) \\ &= \sum_{(d_1, \dots, d_m) \in \mathbf{Z}_+^m} (-q)^{\sum_{ij} C_{ij} d_i d_j} \prod_{j=1}^m \frac{e^{d_j x_j}}{(q^2, q^2)_{d_j}},\end{aligned}$$

$$\text{where } e^{x_i} = q^{n_i} a^{k_i} e^x.$$

**Geometric characters of nodes:**  $C_{ij}$  is linking between disks  $i$  and  $j$ ,  $C_{ii}$  self-linking or framing data for attaching the disk,  $n_i$  is 4-chain intersections (invariant self-linking minus framing),  $(k_i, l_i)$  homology class in  $H_2(X, L_K)$ .

# Basic holomorphic disks and quivers

**After stretching:** The linking  $C_{ij}$  and self-linking  $C_{ii}$  become framings of along the boundary of the basic cylinder. They correspond to attaching data of the neighborhood of basic disks and are determined by normal bundle data. The 'far away' 4-chain intersections lie outside  $N(L_K)$ .

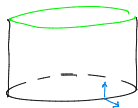

On inside,  $T^*L_K$



On outside,

$X \setminus L_K$

Near breaking



$$\mathcal{O}(-1) \oplus \mathcal{O}(-1) \sim \mathbb{C}^2 \text{ w/ basis } (e^{i\frac{\pi}{2}}, e^{-i\frac{\pi}{2}})$$

# Basic holomorphic disks and quivers

For the unknot the desired form can be obtained from toric geometry.

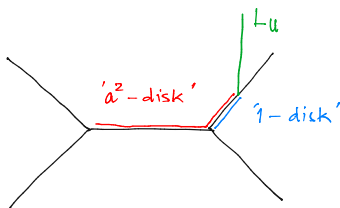

For conormals of other knots basic should come from viewing their conormals as a 'cover' of the unknot conormal and stretching.

# Basic holomorphic disks and quivers

Unknot

$$\begin{array}{cc} \bullet & \bullet \\ e^x & a^2 e^x \end{array}$$

Trefoil

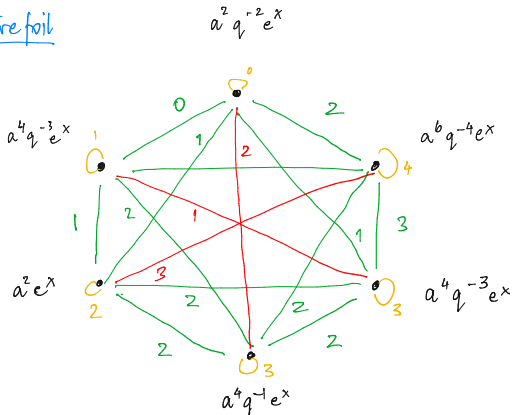



# Non-uniqueness of quivers

Different quivers can give rise to the same partition function.  
There are two main sources.

Canceling pairs

$$\bullet \stackrel{Q^1}{\cong} \stackrel{Q^{-1}}{\cong} = \emptyset$$

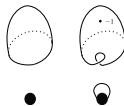

Multi-cover skein

$$\begin{array}{c} \cong \\ \eta \end{array} \begin{array}{c} \bullet^r \\ |^k \\ \circ_s \end{array} = \begin{array}{c} \cong \\ \eta \end{array} \begin{array}{c} \bullet^r \\ |^{r-1} \\ \circ_s \end{array} \begin{array}{c} \bullet^{r+k-1} \\ |^{r+s+2k-1} \\ \bullet \end{array} \begin{array}{c} \bullet^{s+k-1} \\ | \\ \bullet \end{array}$$

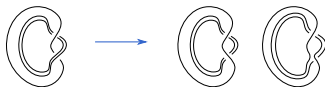

Framing change

$$\begin{array}{c} \bullet^r \\ |^k \end{array} \rightsquigarrow \begin{array}{c} \bullet^{r+|s|^2 \cdot f} \\ |^{k+|s| \cdot f} \end{array}$$

# Basic holomorphic disks and refinement

With inspiration from the M-theory picture  $X \times \mathbf{C}_t \times \mathbf{C}_q \times S^1$  with M5  $L_K \times \mathbf{C}_q \times S^1$  and M2  $\Sigma \times S^1$  and refined curve counting connecting  $\mathbf{C}_t$  to  $N(L_K)/J(TS^1)$  and then  $N(S^1)$ , consider the refined partition function:

$$\Psi_K(e^x, a, q, t) = \sum_{(d_1, \dots, d_m) \in \mathbf{Z}_+^m} q^{\sum_{ij} C_{ij} d_i d_j} \prod_{j=1}^m \frac{e^{d_j x_j}}{(q^2, q^2)_{d_j}},$$

$$\text{where } e^{x_i} = q^{n_i} a^{k_i} t^{C_{ii}} e^x.$$

Then the refined partition function is not invariant under removing canceling pairs and the  $e^x$ -term  $\Psi_K^{(1)}(a, q, t)$  is the Poincaré polynomial of HOMFLY-homology.

**The unknot:**

$$\frac{1}{1 - q^2} (1 + ta^2).$$

**The trefoil:**

$$\frac{1}{1 - q^2} (a^2(t^2 + q^{-2}) + a^4(q^{-1}t^3 + q^{-3}(t + t^3)) + a^6q^{-4}t^4).$$

For simple knots this continues. Higher terms in the refined partition function gives the Poincaré polynomial of the corresponding symmetrically colored HOMFLY homology

**The unknot:**

$$\frac{1}{(1 - q^2)(1 - q^4)\dots(1 - q^{2d})} \left( \sum_{k=0}^d \binom{d}{k} a^{2k} t^k \right).$$

# Basic holomorphic disks and refinement

Geometrically this means we express the defect in the  $U(1)$  Chern-Simons on  $L_K$  in a specific basis of the skein, as if every contribution comes from covers of a basic disk.

On level 2 :

$$\left( \frac{1}{2} \text{[disk with 2 dots]} + \frac{1}{2} \text{[disk with 1 dot]} \right) \\ \frac{1}{2} \frac{1}{(1-q^2)^2} + \frac{1}{2} \frac{1}{(1-q^4)} = \frac{1}{(1-q^2)(1-q^4)}$$

On level 3 :

$$\frac{1}{6} \text{[3 disks]} + \frac{1}{2} \text{[2 disks]} + \frac{1}{3} \text{[1 disk]}$$

etc.

# Basic holomorphic disks and refinement

For not so simple knots this breaks. For example for  $9_{42}$

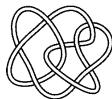

we have (the reduced) super polynomial

$$\begin{aligned}\tilde{\Psi}_{9_{42}}^{(1)}(a, q, t) &= P_{9_{42}}^1(a, q, t) \\ &= a^{-2} \left( \frac{1}{q^2 t^2} + q^2 \right) + \left( q^4 t^3 + \frac{1}{q^4 t} + 2t + 1 \right) \\ &\quad + a^2 \left( q^2 t^4 + \frac{t^2}{q^2} \right).\end{aligned}$$

But

$$P_{9_{42}}^2(a, q, t) = a^{-6} (\text{twelve monomials}) + \dots$$

# New basic holomorphic curves

We propose new generators at level  $d$  in the stretched picture: a  $d$ -fold cylinder over the geodesic with an embedded sphere on the outside at the Reeb orbit.

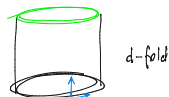

On inside



On outside



$$\exp\left(\sum_{k=1}^{\infty} \frac{1}{k^d} \frac{x^{kd}}{(1-q^{2kd})}\right)$$

$$\exp\left(\sum_{k=1}^{\infty} \frac{1}{k^d} \frac{x^{kd}}{(1-q^{2kd})}\right)$$

Recursion relation

$$(1 - e^{\hat{y}} - e^{d\hat{x}})\psi_d = 0.$$

# New basic holomorphic curves

At the refined level we should take into account framing data at the boundary. A basic disk comes with a standard Lagrangian boundary condition that is naturally trivialized connecting  $(v_1, v_2)$  to  $(-v_1, -v_2)$ . Depending on the sense of rotation the new basic objects at level  $d$  contributes to the refined level  $d$  superpolynomial as

$$\xi \cdot \frac{(1 + t^\pm q^2)(1 + t^\pm q^4) \dots (1 + t^\pm q^{2d-2})}{(1 - q^2)(1 - q^4) \dots (1 - q^{2d})}.$$

Here  $\xi = e^{dx} a^k q^m t^{C_{ii} \pm 1}$ , where  $C_{ii}$  refers to the self linking of the attaching map (the underlying once around curve).



# New basic holomorphic curves

In general the contribution to both the standard and refined partition functions can be written much as before in terms of internal charges  $\xi$  and linking information  $C_{ij}$ . E.g.,

$$q^{2C_{ij}d_1k_1d_2k_2} \frac{\xi_1^{k_1}}{(1 - q^{2d_1}) \dots (1 - q^{2k_1d_1})} \frac{\xi_2^{k_2}}{(1 - q^{2d_2}) \dots (1 - q^{2k_2d_2})}$$

and on the refined level add factors  $\frac{1+t^\pm q^{2s}}{1-q^{2s}}$  to 'correct' denominators.

# New basic holomorphic curves – test

A test of the proposal: the part of the level 2 super polynomial that does not come from level one basic disks should contain factors  $(1 + t^{\pm}q^2)$ . For  $9_{42}$  we have the second level super-polynomial:

$$\begin{aligned} P_2(a, q, t) = & 1 + (q^2 + 1) \left( \frac{1}{a^2 q^4 t^3} + 1 \right) \left( \frac{q^2}{a^2 t} + 1 \right) \left( a^2 q^2 t^4 + \frac{a^2 t^2}{q^2} \right) \\ & + (q^2 + 1) \left( \frac{1}{a^2 q^6 t^3} + 1 \right) \left( \frac{1}{a^2 q^4 t^3} + 1 \right) \left( \frac{q^2}{a^2 t} + 1 \right) \\ & \cdot (a^2 q^6 t^6 + a^2 q^6 t^5 + a^4 q^4 t^6 + 2a^2 q^2 t^5 + a^2 t^4 + q^2 t^4 + t^3) \\ & + (q^2 + 1) \left( \frac{1}{t} + 1 \right) \left( \frac{1}{a^2 q^6 t^3} + 1 \right) \left( \frac{1}{a^2 q^4 t^3} + 1 \right) \left( \frac{q^2}{a^2 t} + 1 \right) \\ & \cdot (a^4 q^8 t^8 + a^2 q^8 t^7 + a^2 q^4 t^5 + a^4 q^2 t^6 + a^2 t^4 + q^6 t^5 + t^3) \\ & + \left( \frac{1}{a^2 t} + 1 \right) \left( \frac{1}{a^2 q^6 t^3} + 1 \right) \left( \frac{1}{a^2 q^4 t^3} + 1 \right) \left( \frac{q^2}{a^2 t} + 1 \right) \\ & \cdot (a^4 q^{12} t^8 + a^4 t^4) \end{aligned}$$

# New basic holomorphic curves – test

Subtracting the contribution from level one disks leaves:

$$\begin{aligned} P_2 - P^0|_{x^2} = & a^{-6} \left[ \left( \frac{1}{q^6 t^4} + \frac{1}{q^8 t^4} + \frac{1}{q^8 t^5} + \frac{1}{q^2 t^5} \right) (q^2 t + 1) + \left( \frac{1}{q^8 t^4} + \frac{1}{q^2 t^2} \right) \left( \frac{q^2}{t} + 1 \right) \right] \\ & + a^{-4} \left[ \left( \frac{1}{q^2 t^2} + \frac{2}{q^4 t^2} + \frac{1}{q^4 t^3} + \frac{1}{q^6 t^3} + \frac{2}{q^8 t^3} + \frac{1}{q^{10} t^4} + \frac{2}{q^2 t} + q^4 + q^2 + \frac{2}{t} \right) (q^2 t + 1) \right. \\ & \left. + \left( \frac{q^2}{t} + 1 \right) \left( \frac{1}{q^4 t^2} + \frac{1}{q^8 t^2} + \frac{1}{q^8 t^3} + \frac{2}{q^{10} t^3} + q^4 t + q^2 t + \frac{2}{q^2 t} + \frac{3}{q^4 t} + \frac{1}{q^2} + 1 \right) \right] \\ & + a^{-2} \left[ (q^2 t + 1) \left( q^8 t^3 + q^8 t^2 + q^6 t^2 + 2q^4 t^2 + \frac{2}{q^6 t^2} + \frac{1}{q^8 t^2} + \frac{1}{q^{10} t^2} + \frac{1}{q^{10} t^3} + 3q^2 t + \frac{3}{q^4 t} + \frac{2}{q^6 t} + \frac{1}{q^8 t} + \frac{4}{q^2} + \frac{2}{q^4} + 2t + 3 \right) \right. \\ & \left. + \left( \frac{q^2}{t} + 1 \right) \left( q^8 t^4 + 2q^4 t^3 + q^4 t^2 + 3q^2 t^2 + \frac{1}{q^{10} t^2} + \frac{3t}{q^2} + \frac{t}{q^4} + \frac{2}{q^6 t} + \frac{3}{q^4} + \frac{1}{q^6} + t^2 + 3t \right) \right] \\ & + a^0 \left[ (q^2 t + 1) \left( q^{10} t^5 + q^8 t^4 + 4q^6 t^3 + 5q^4 t^3 + q^4 t^2 + 3q^2 t^3 + 2q^2 t^2 + q^2 t + \frac{4t}{q^2} + \frac{2t}{q^4} + \frac{1}{q^8 t} + \frac{2}{q^6} + 2t^2 \right) \right. \\ & \left. + \left( \frac{q^2}{t} + 1 \right) \left( q^{10} t^6 + 2q^8 t^5 + q^6 t^5 + 2q^6 t^4 + q^2 t^3 + \frac{5t^2}{q^2} + \frac{2t^2}{q^4} + \frac{2t}{q^6} + \frac{1}{q^8} + 2t^3 \right) \right] \\ & + a^2 \left[ (q^2 t + 1) \left( q^{12} t^6 + q^{10} t^6 + q^8 t^6 + q^6 t^5 + 2q^6 t^4 + 2q^4 t^4 + 2q^2 t^4 + \frac{t^2}{q^2} + \frac{t^2}{q^4} + t^4 + t^3 + t^2 \right) \right. \\ & \left. + \left( \frac{q^2}{t} + 1 \right) \left( q^8 t^7 + q^6 t^6 + q^4 t^5 + 2q^2 t^5 + \frac{t^3}{q^4} + t^4 \right) \right] \\ & + a^4 \left[ (q^2 t + 1) (q^8 t^7 + q^2 t^5) + \left( \frac{q^2}{t} + 1 \right) (q^8 t^8 + q^2 t^6) \right] \end{aligned}$$

# New basic holomorphic curves – test

In summary the number of generators are

	$a^{-6}$	$a^{-4}$	$a^{-2}$	$a^0$	$a^2$	$a^4$
$P_2$	12	60	124	129	64	12
$P^Q _{x^2}$	0	4	20	33	20	4
# new	6	28	52	48	22	4

Also  $10_{132}$



passes the test.

	$a^0$	$a^2$	$a^4$	$a^6$	$a^8$	$a^{10}$	$a^{12}$
$P_2$	36	172	352	384	237	80	12
$P^Q _{x^2}$	0	0	16	40	41	20	4
# new	18	86	168	172	98	30	4

The proposal also passes other checks on the unrefined level.

# New basic holomorphic curves

The main conjecture is that for any knot there is an essentially unique finite collection of basic curves with linking, self-linking, and 4-chain intersection that determine symmetrically colored HOMFLY homology (via its partition function).

There is also (unrefined) versions of this where linking and self-linking is upgraded to  $Sk(L_K)$ .

THANK YOU !